

Top View of Assembly

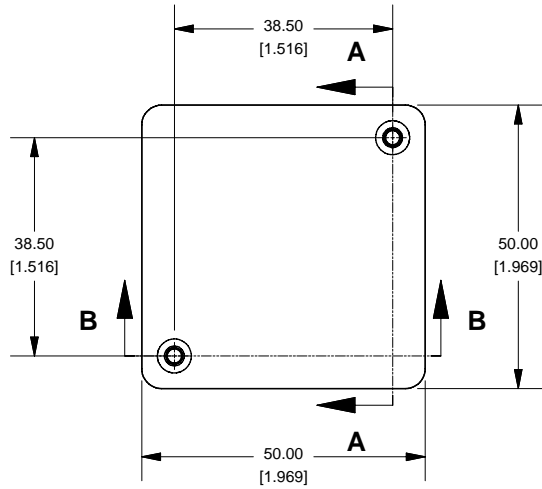

SECTION A-A End View of Assembly

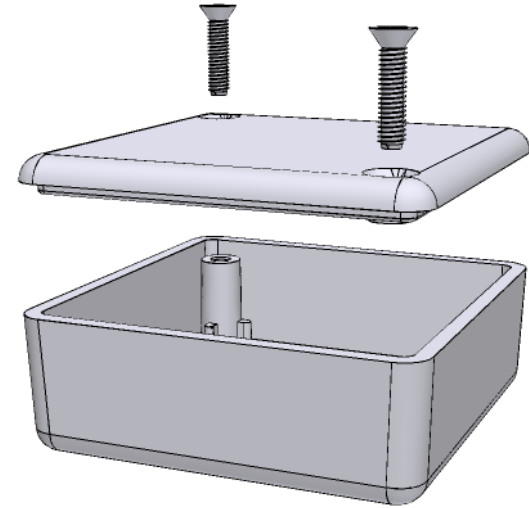
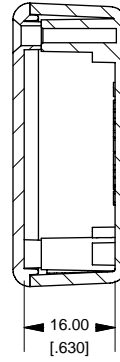

SECTION B-B Side View of Assembly

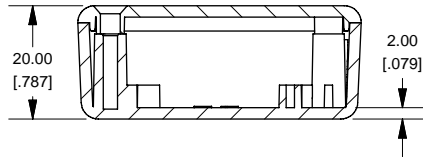

Top View Looking Inside Box

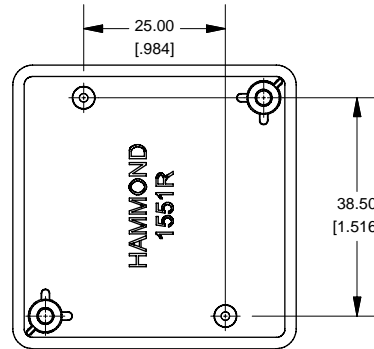

Lid

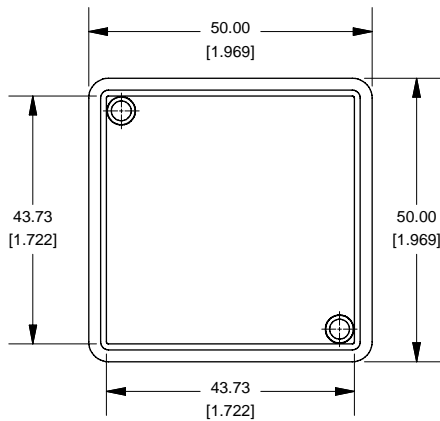

SECTION C-C Boss Heights

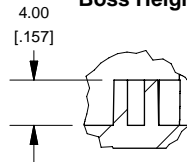

Maximum P.C. Board Size

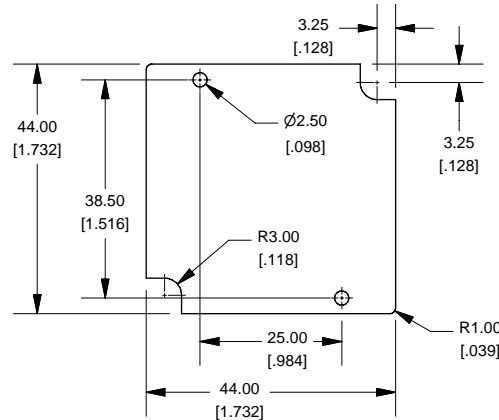

NOTE

Purchased assembly includes lid and box made from GP ABS material and cover screws.

1551R

1551R Flange Enclosure

Black Enclosure - RAL 7001 - UL94 - HB	1551RHBK
Gray Enclosure - RAL 7035 - UL94 - HB	1551RGY
Translucent Blue - UL94 - HB	1551RTBU

ACCESSORIES

Black Enclosure Cover Screws (Pkg 100) [#4 X 1/2" Self Tapping]	1591TS100BK
Grey Enclosure Cover Screws (Pkg 100) [#4 X 1/2" Self Tapping]	1591TS100
P.C. Board Screws (Pkg 100) [32 x 3/16" Self Tapping]	1551ATS100

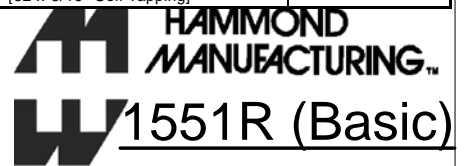

www.hammondmfg.com